

Musical Sound For Imposing Spaces

Public buildings are designed to convey strong messages. But the high ceilings and reflective surfaces of institutional architecture produce long reverberation times, making it difficult for people to hear and communicate clearly. Iconyx Digitally Steerable Arrays are the first sound systems that enable both effective communication and expressive musical artistry. Iconyx does all of this without compromising the architectural statement of the building itself.

The transparent design of Iconyx integrates high-performance acoustical components, advanced, audiophile-quality digital electronics and powerful software in practical, modular systems that virtually disappear in most large buildings. Iconyx is the first solution to combine digital steering with exceptional audio fidelity.

Lessons derived from hundreds of successful projects are reflected in the second generation "A" Series Iconyx array modules. Advanced signal processing algorithms and purpose-designed coaxial transducers with dual tweeters provide even more clarity, musicality and intelligibility.

Transparent Solutions

- Houses of Worship: traditional & modern
- Transport Terminals: train stations, airports, etc.
- Stadiums & Arenas: lobbies & forecourts
- Convention Centers, warehouses, etc.
- Museums: lobbies, galleries, etc.
- Performing Arts Centers: vocal/orchestral "lift," lobbies, etc.
- Any highly reverberant environment where enjoyable music and/or intelligible speech are as important as the architectural design

MUSICAL • INTELLIGIBLE • PRACTICAL

High Performance Amplifiers Drive Coaxial Transducers

Control is pointless unless the sound is accurate, natural and enjoyable. That's why Iconyx uses multi-channel audiophile high-current amplifiers to power arrays of advanced, purpose-designed coaxial transducers, each one having its own high frequency tweeter array.

Individual Transducer Control

Iconyx' Transparent Technology controls acoustic energy using silicon intelligence, not bulky, brute-force techniques. Multi-channel Class D digital amplifiers with integral DSP engines control every single Iconyx array element with total precision. The high-current output section maximizes audio accuracy.

Ultimate Flexibility – Multiple Beams and Movable Acoustic Centers

Iconyx Technology gives sound system designers the power to cover almost any audience area perfectly. Up to 12 separate sonic beams can be individually shaped and aimed from a single IC24A Iconyx array. The acoustic center of each beam can be raised or lowered electronically.

Intuitive Software

Total control doesn't require bewildering complexity. Iconyx BeamWare™ combines order and simplicity, performing complex mathematical calculations behind an intuitive graphical user interface.

Architecturally Transparent

The tall, slim Iconyx enclosure is designed to be heard but not seen. Modular Iconyx arrays are easily assembled on site. They mount flush to walls and columns, blending invisibly with almost any architectural style. Yet Iconyx technology aims the sound precisely at the audience, and nowhere else.

Digitally Steerable Loudspeaker Array Systems



IC24A



Give the IC24A six inches (15 cm) of wall space, and it will give everyone within 195 feet (60 m) over 100 dB of beautifully detailed, naturally balanced full range sound.

MUSICAL & NATURAL

Natural Speech, Enjoyable Music

Communication is about more than consonants – meaning is conveyed by the tone of voice as well as the text. We also believe that beautiful spaces deserve beautiful music. That's why Iconyx-A modules use an audiophile-quality multi-channel amplifier to drive purpose-designed coaxial transducers with dual tweeters. Each pair of tweeters is aligned vertically, acting as an "array within an array." By controlling vertical directivity at higher frequencies, they produce a more coherent output with greatly reduced high frequency grating lobes.



Coaxial transducers with dual tweeters developed specifically for use in ICONYX A series arrays reduce grating lobes..

The vertical alignment maintains consistently broad horizontal dispersion, allowing each Iconyx array to cover a wider section of the audience. The coaxial transducers reproduce the full frequency spectrum with accuracy and balance, so instruments and voices sound as they should. In many venues, Iconyx arrays and subwoofers will bring music alive with full detail and impact throughout the entire listening area.

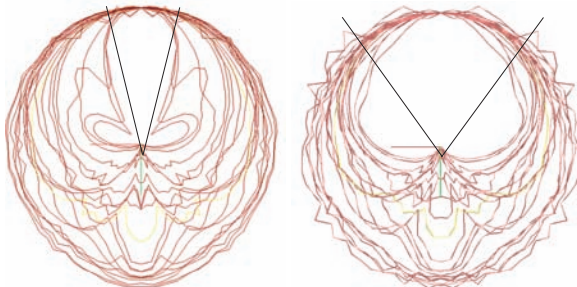

Conventional Transducer IC Coaxial Transducer
Coaxial transducers provide more consistent horizontal coverage, broader HF beamwidth

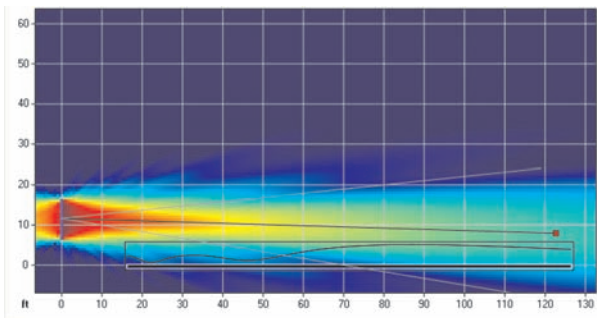

BeamWare display of an IC24A illustrating the reduced grating offered by ICONYX IC-A series arrays with their improved algorithms and dual HF tweeters.

CLEARLY INTELLIGIBLE

Intimate Sound for Imposing Spaces

"Up close and personal" communication happens when sound arriving directly from the source, whether it's a live person or a loudspeaker, is much louder than sound that's reflected off the walls, windows, floor and ceiling. As you move farther away, the direct sound loses volume twice as fast as the reflected sound. In very reverberant spaces, it can be hard to understand someone speaking in a normal tone of voice more than a couple of arm's lengths away.

Iconyx arrays produce tightly focused, precisely aimed beams of acoustic energy that retain their intensity over long distances. Because most of the highly directional sound from an Iconyx array is focused on the listeners, very little is left to bounce around the room and confuse the ears. That's how Iconyx arrays let you sit hundreds of feet away from the speaker or musicians and still hear words and music as if they were right "in your face."

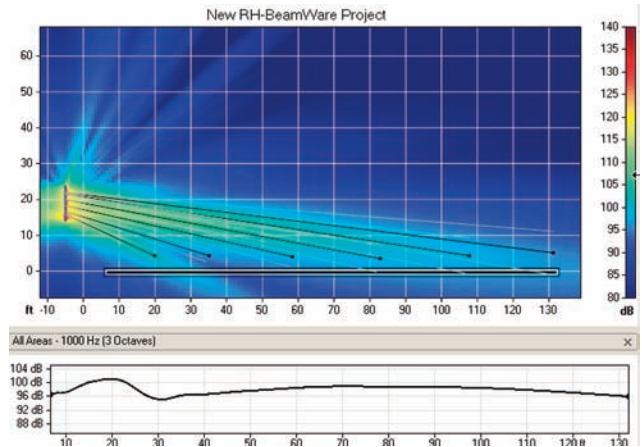

Beamware display showing the multi-beam and movable acoustic centers capabilities of the IC24A Iconyx array.

Expandable Modular Systems

The 112 inch tall IC24A has 24 transducers and provides tight control of acoustic energy above 250 Hz, and can provide high output, high definition audio at distances of 195 feet with very tight 5 degree beams. It is ideal for very large public spaces such as transportation centers, theme parks, warehouses, and cathedrals, or for any highly reverberant space.

The IC24A has 24 DSP controlled digital amplifier channels (one for each transducer) and delivers a peak SPL of 102 dB at 100 feet. It provides consistent pattern control down to 250 Hz. That's pretty amazing, but it doesn't mean that Iconyx breaks the rules of acoustics. The frequency range of effective control is set by the height of the array (on the low end) and the spacing between transducers (on the high end).

To suit different needs, Iconyx systems are available in four sizes: all are constructed from a basic eight-channel module to simplify shipping and transportation. Iconyx systems can also be easily expanded at a later date by simply adding modules. The modules are easily transported and quickly joined together in the field: a single module forms the IC8A, two modules form the IC16A, three the IC24A and four the IC32A.

All bring high output, crisply articulated, naturally balanced sound to every listener.



Sophisticated Design

Every building is different: and so is every Iconyx system – we've engineered a flexible, modular platform that gives designers the most accurate and adaptable system in history. The basic building block of the IC24, and every other Iconyx array, is the 8-channel IC8A linear array module (each channel comprises a DSP, amplifier and transducer).

D2 DSP Processor/Amplifier



The brain of each IC8A module is the 8-channel DSP processor/amplifier developed specifically for Iconyx. Its audiophile, high-current output section and integral DSP engine control each high-performance coaxial transducer with total precision. Each driver receives an individually filtered and delayed signal, so that the array can

produce the specified beams and steering angles. The Class D digital amplifiers are lightweight, efficient and cool: no fan noise. AC supply voltages of 90 to 260 V, 50/60 Hz are automatically accepted.

Digital CobraNet

Iconyx is designed for today's networked audiovisual environments. In addition to its standard analog inputs an optional Cobranet input module may be added. This allows the user to select from up to 64 channels of PCM digital audio delivered on a CobraNet network via Cat 5 copper cable.

Intuitive Software

The software algorithms that shape and aim the output of an Iconyx array are complex, but the user interface is intuitively simple. Our Beamware Windows application lets you define the audience area, then adjust the beams until coverage is optimized. Beamware then produces a set of FIR (Finite Infinite Response) filters that control the array. At installation time, simply download the full set of FIR filters to the IC Series modules using one of your computer's COM ports and a USB-to-RS232 adapter.

Beamware data can also be transferred to EASE 4.X, the industry-standard modeling program, for 3D simulation and analysis.

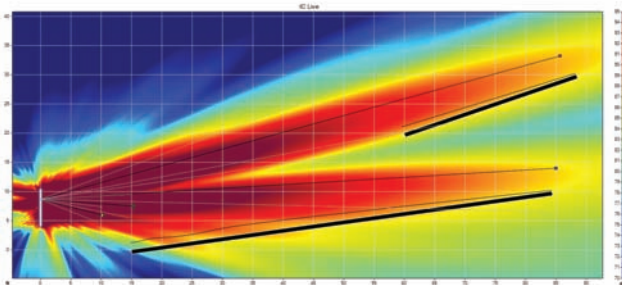

Beamware display of an Iconyx IC16 array's dual beam output..

Beamware calculations have been verified by actual measurements in our test facility and in real world installations. But there's still room for last-minute adjustments if needed. If an array is hung too low, simply raise its acoustical center in software.

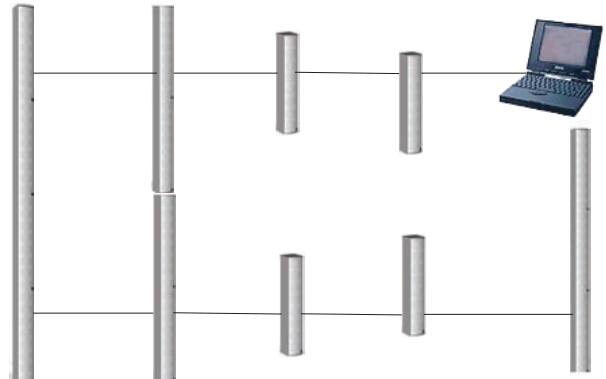

Iconyx software lets you adjust installed arrays by moving acoustic centers, setting output level and applying EQ. Each COM port on your PC or laptop links with up to 8 IC Series arrays.

Ease of installation

Iconyx is designed to install quickly and cleanly, with hinged mounting hardware that facilitates signal and power connections and allows precise horizontal aiming. After installation and commissioning, the array can be locked in place.

The extruded aluminum Iconyx enclosure includes a recessed chamber where connecting cables can be neatly tucked away out of sight.

An optional removable access plate with a conduit knockout provides easy access to the IEC power connector and "pig tail".

Removable side panels and grille allow easy access to the coaxial transducers and the DSP processor/amplifiers for testing and service.

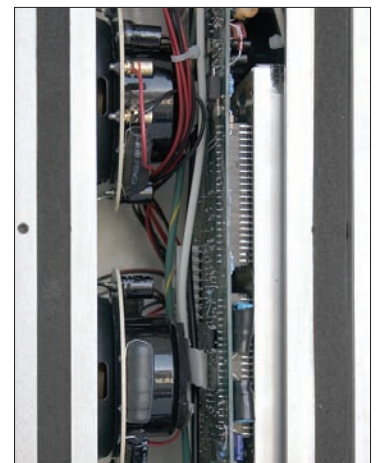



IC24A Technical Specs

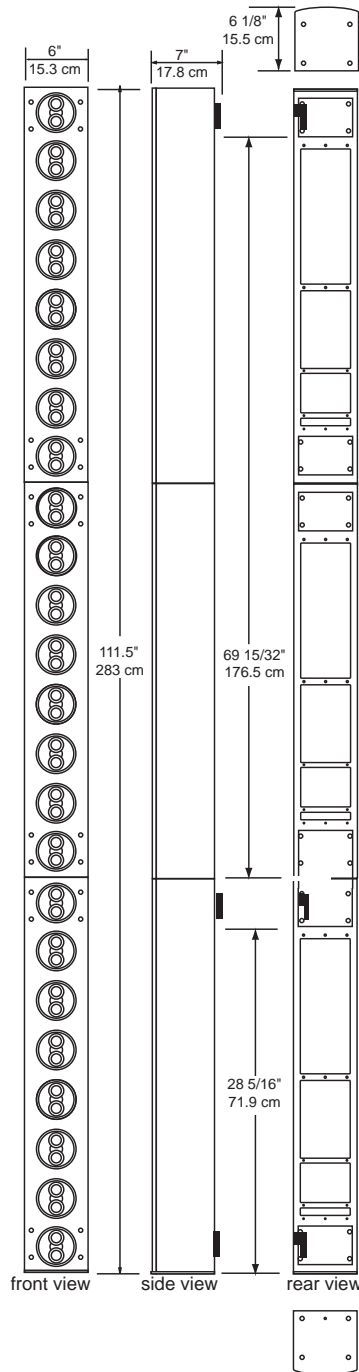

Sensitivity: 1.0 V (for rated power output)

Freq. Range: 120 Hz to 18 kHz

Max SPL: 102 dB peak, 99 dB pgm @ 100 Ft. (30.5 meters)
(3-octave bandwidth centered @ 2 kHz)

Horiz. Dispersion: 150° up to 3 kHz; 120° above 3 kHz

Vert. Dispersion: 5°, 10° and 15°

Aiming Angle: adjustable from -30° to +30°

Typical Throw: 195 Ft. (60 meters)

Beam Control: Effective down to 250 Hz

No. Transducers: 24

No. Amp. Channels: 24

Dimensions (With Mounting Hinges): 111.5" H x 6" W x 7" D (283 cm x 15.3 cm x 17.8 cm)

Weight: 105 Lbs (47.6 Kg)

Power Required: 72 VA Idle; 975 VA @ rated output

Hanging Method: 3-point hinge or eye-bolts.

Enclosure: Extruded Aluminum with perforated steel grille; suitable for outdoor use.

Transducers: Coaxial with a 4" woofer and dual 1" tweeters, RH model SSL4-3; 25 Watts RMS, 50 Watts program

Connectors: Audio Input: Phoenix 3-pin (looping 3-in, 3-out)
DSP programming: 9-pin DB-9 connector plus looping 7-pin Phoenix connector.
Power: IEC power connector

Finish: Standard finish: white paint
Optional finishes: black and custom color paint

DSP/AMPLIFIER

Type: 8-channel, Class D amplifier/DSP processor

Power Rating: 50 Watts RMS per channel, 150 Watts Burst

Freq. Range: + 3, - 3 dB, 20 Hz to 20 kHz

THD Distortion: < 0.05% typical

Hum & Noise: <100 dB (A weighted)

Inputs: 10K Ohm balanced differential (standard)
CobraNet or AES/EBU (optional)

Input Sensitivity: 1.0 V for rated power output

CMR: 74 dB

Gain: DSP controlled, 0 to -60 dB in 1 dB steps

EQ: 8-band Parametric

Power: Universal 90/260 VAC, 50/60Hz.
2.4 A @ 120 V; 1.2 A @ 240 V

Idle Current: 200 mA @ 120 V; 100 mA @ 240 V

Max Inrush Current: 10 A