

## Uncompromising Performance, Unequaled Versatility

Self-powered PowerNet PN and non-powered PNX Series loudspeakers unite advanced technology and application-driven engineering to bring live sound closer to the ultimate reference point: reality. Cutting edge driver technology and unique innovations such as our Complex Conic driver technology and unique innovations such as our Complex Conic horns deliver natural sounding music and intelligible speech. Advanced options like intelligent onboard amplification and RHAON - the Renkus-Heinz Audio Operations Network - help you build sophisticated sound systems that are easy to use. Wherever audiences and operators demand superior performance and ease of use, PN/PNX loudspeakers are the choice for transparent, reference quality performance.

All PN and PNX series loudspeakers are handcrafted especially for you in our Foothill Ranch, California facility. Numerous custom options are available.

### Applications

- Virtually any application where directional control and arrayability are critical issues and reference quality sonic performance is required.

### Permanent Installations

- Ideal for live music and speech reinforcement, club/disco systems and high power distributed systems.
- Churches, schools, performing art centers, night clubs, stadiums and arenas.

### Portable Applications

- Ideal for live music and speech reinforcement, portable DJ systems and high output distributed systems.
- Rental A/V, DJ systems, churches, schools, etc.



### PN-1/PN-1R PowerNet Amplifiers

The PN-1, the heart of PowerNet performance, is a new kind of intelligent electronics system. It combines low feedback Class A/B amplification and comprehensive signal processing into a single compact unit. Crossovers and parametric EQ are integrated into the signal path. Loudspeaker specific processing senses when output levels are about to damage the system and limits them to safe levels.



The PN-1R adds RHAON, the Renkus-Heinz Audio Operations Network. RHAON empowers you with full control over digital audio distribution, loudspeaker specific DSP and remote control/ monitoring -- all using standard Ethernet hardware and cable.

The PN-1R has dual analog inputs, dual CobraNet inputs and an AES3id serial input. The onboard DSP is easily configured using RHAON software; it includes eight bands of parametric EQ, high and low shelving filters, delay and input level control. Critical operating parameters such as signal clipping, amplifier output voltage and current, and temperature are continually monitored with automatic alert functions.

If you need a reference quality 15-inch 2-way system, order the PNX151T/A or the PN151. If you need Ethernet-based audio operations networking, order the RHAON empowered PN151R.

## PN/PNX Series

### PNX151

Non-Powered

### PN151

Self-Powered

## 15" Woofer - 2" HF 2-Way Complex Conic Loudspeakers

**ACTIVE • POWERED • NETWORKED  
MAXIMUM CONTROL • MAXIMUM CHOICE**



- **Reference Quality, High-Output 2-Way Systems**  
Accurate full-range 40 Hz to 18 kHz; 131 dB peak SPL performance.
- **Exclusive Complex Conic Design**  
Provides constant beamwidth/directivity without the problems of conventional rectangular horns; have extended bandwidth, lower distortion and minimal coloration.
- **RHAON Renkus-Heinz Audio Operations Network**  
Self-powered PN151R cabinets include RHAON for flexible digital signal distribution, loudspeaker management & control.
- **PNX151T/A Non-Powered Loudspeakers**  
Are active loudspeakers for "no-compromise" performance and greater versatility. Weather resistant models are available.
- **PN151 PowerNet Self-Powered Loudspeakers**  
Include the PN-1 Class A/B amplifier with loudspeaker specific signal processing and protection.
- **Choice of Coverage Patterns**  
Choose between 90° by 40°, 60° by 40° and 40° by 40° coverage.
- **TRAP (True Array Principle) Design**  
All PN & PNX151/4A models are true 40° TRAP modules. TRAP array geometry aligns acoustic centers, so modules combine seamlessly to produce a phase aligned wavefront virtually free of lobing.

## TECHNICAL INFORMATION

**Sensitivity:** PN151 - 1.4 Volt for RPO  
PN151R; 1.0 Volt for RPO  
**PNX151T/A:** 98 dB (1W/1m)

### Max SPL

**PN151 & PN151R:** 125 dB program, 128 dB peak  
**PNX151T/A:** 128 dB program, 131 dB peak

**Dispersion:** 40° H by 40° V, 60° H by 40° V, 90° H by 40° V

**Freq. Response:** 40 Hz to 18 kHz

**HF Driver:** 2" SSD3302-8A driver, 8 Ohms;  
75 W RMS, 150 W program

**LF Driver:** 15" model SSL15-11, 500 W RMS @ 4 Ohms, 1000 W program

**Enclosure:** Multi-ply hardwood, perforated metal grille

**Power – PN151 & PN151R:** 115 V AC or 230 V AC, 50/60 Hz

**PNX121T/A:** Highs; 150 W pgm at 8 Ohms  
Lows; 1000 W pgm at 4 Ohms

**Connectors – PNX151T/A:** Screw terminals & looping Neutrik 4-pin SpeakOn style connectors

**Finish:** Black, white or custom color paint  
Natural (unfinished)  
Weather Resistant

**Hardware Options:** 12-point univ. mtg. hdw. (Metric M10 threads)  
U-bracket attachment points, Tripod socket,  
PN Weather Resistant Kit, Aeroquip Flytrack

**Dimensions:** 29 1/2" H x 19" W x 18 1/2" D  
(74.9 cm x 48.3 cm x 47 cm)

**Weight– PN151 & PN151R:** 88 Lbs (39.9 Kg) net

**PNX151T/A:** 78 Lbs (35.4 Kg) net

## PN-1 AMPLIFIER

**Power Rating:** 300 W RMS @ 8 Ohms

**Freq. Response:** +0.0, -5 dB, 20 Hz to 20 kHz

**THD Distortion:** < 0.02% typical

**Hum & Noise:** <100 dB (A weighted)

**Damping:** >100

**Input:** 10K Ohm balanced differential

**Sensitivity:** 1.4 V for RPO

**CMR** 74 dB

**Controls:** Gain (screwdriver adjustable)

### Connectors

**Input:** Looping XLR; female in, male out (pin 1 chassis, pin 2 +, pin 3 -)

**Power:** IEC Power connector

**Power:** 90-136 VAC or 180-260 VAC 50/60Hz.  
4 A @ 120 V, 2 A @ 240 V  
Idle current: 300 mA @ 120 V;  
150 mA @ 240 V  
Max inrush current: 10 A

## PN-1R RHAON EMPOWERED AMPLIFIER

The PN-1R amplifier is identical to the PN-1 except for the addition of the RHAON Network Interface; additional capabilities include:

**Inputs:** CobraNet; dual RJ45 connectors; accept CAT 5 copper cable.  
AES/EBU; Phoenix connectors;  
Analog; Phoenix connectors

**Digital Format:** 16, 20 or 24 bit PCM; 48 or 96 kHz sample rate; selectable Network Latency.

**Protection:** Soft & Peak Limiting, Excursion Control & Thermal Regulation

For additional details on the RHAON Audio Operations Network, refer to [www.renkus-heinz.com/Rhaon/Index.html](http://www.renkus-heinz.com/Rhaon/Index.html)

Note: All analog inputs and outputs comply with AES Standard 48-2005 on interconnecting, grounding and shielding.

## DIMENSIONAL INFORMATION

UMH (Universal Mounting Hardware) attachment points are standard on all fixed installation models. The points have Metric M10 threads and are positioned 1 3/4" from the edges unless otherwise indicated. A nut-plate for Omnimount Series 120 mounting hardware may be substituted for the UMH points; can be either top, bottom or side mounted. U-bracket attachment points are a third option.

Portable models are normally supplied with a tripod socket and no attachment points. AeroQuip fly-track, top and bottom mounted, is another option.

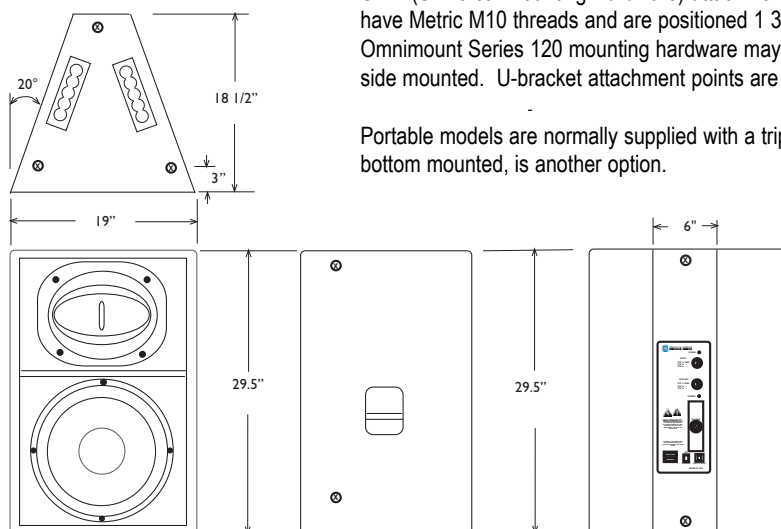

Note:

The rear view of a PN151 is shown. The enclosure is shown without its metal grille.

For more detailed dimensional information, please refer to the 2D and 3D drawing files on our website, [www.renkus-heinz.com](http://www.renkus-heinz.com).