



Uncompromising Performance, Unequaled Versatility

Self-powered PowerNet PN and non-powered PN Series loudspeakers unite advanced technology and application-driven engineering to bring live sound closer to the ultimate reference point: reality. Cutting edge driver technology and unique innovations such as our Complex Conic horn technology and unique innovations such as our Complex Conic horns deliver natural sounding music and intelligible speech. Advanced options like intelligent onboard amplification and RHAON - the Renkus-Heinz Audio Operations Network - help you build sophisticated sound systems that are easy to use. Wherever audiences and operators demand superior performance and ease of use, PN/PNX loudspeakers are the choice for transparent, reference quality performance.

All PN and PNX series loudspeakers are handcrafted especially for you in our Foothill Ranch, California facility. Numerous custom options are available.

Applications

- Virtually any application where size is a critical issue and reference quality sonic performance is required.

Permanent Installations

- Ideal for many side and front fill applications; mounts inconspicuously on walls or ceilings, stage lips, under balconies, etc.
- High quality speech and music systems, surround sound systems, conference room systems, etc.

Portable Applications

- A/V rentals; portable sound systems for performing artists and lecturers, small bands, choral groups, etc.



PN-1/PN-1R PowerNet Amplifiers

The PN-1, the heart of PowerNet performance, is a new kind of intelligent electronics system. It combines low feedback Class A/B amplification and comprehensive signal processing into a single compact unit. Crossovers and parametric EQ are integrated into the signal path. Loudspeaker specific processing senses when output levels are about to damage the system and limits them to safe levels.



The PN-1R adds RHAON, the Renkus-Heinz Audio Operations Network. RHAON empowers you with full control over digital audio distribution, loudspeaker specific DSP and remote control/ monitoring -- all using standard Ethernet hardware and cable.

The PN-1R has dual analog inputs, dual CobraNet inputs and an AES3id serial input. The onboard DSP is easily configured using RHAON software; it includes eight bands of parametric EQ, high and low shelving filters, delay and input level control. Critical operating parameters such as signal clipping, amplifier output voltage and current, and temperature are continually monitored with automatic alert functions.

If you need a versatile reference quality 2-way system, order the PNX82 or the PN82. If you need Ethernet-based audio operations networking, order the RHAON empowered PN82R.

PN / PNX Series

PNX82

Non-Powered

PN82

Self-Powered

Dual 8" Woofer - 1" HF 2-Way Complex Conic Loudspeakers

PASSIVE • POWERED • NETWORKED
MAXIMUM CONTROL • MAXIMUM CHOICE



• Reference Quality, High-level 2-Way Systems

Accurate full-range 60 Hz to 18 kHz; 127 dB peak SPL performance from surprisingly compact loudspeakers.

• Exclusive Complex Conic Horn Design

Provides constant beamwidth/directivity without the problems of conventional rectangular horns; offers superior pattern bandwidth, low distortion and more natural sound; can be rotated 90° within the cabinet for wide or deep listening spaces.

• RHAON - Renkus-Heinz Audio Operations Network

Self-powered PN81R cabinets include RHAON for flexible digital signal distribution, loudspeaker management & control.

• PNX82 Non-Powered Loudspeakers

Built-in crossover eliminates the need for a separate electronic crossover and bi-amplification. Weather resistant models are available.

• PN82 PowerNet Self-Powered Loudspeakers

Include the PN-1 Class A/B amplifier with loudspeaker specific signal processing and protection.

• Choice of Coverage Patterns

Choose between 90° by 60° and 120° by 60° coverage.

• Choice of Finishes

PN and PNX Series loudspeakers are available in black, white or custom colors.

TECHNICAL INFORMATION

Sensitivity:

PN82: 1.4 Volt for RPO

PN82R: 1.0 Volt for RPO

PNX82: 97 dB (1W/1m)

Max SPL:

PN82 & PN82R: 124 dB program, 127 dB peak

PNX82: 125 dB program, 128 dB peak

Dispersion: 90° H by 60° V & 120° H by 60° V

Freq. Response: 60 Hz to 18 kHz

HF Driver: 1" SSD1803-8 driver, 8 Ohms;

40 W RMS, 80 W program

LF Driver: Dual 8" model SSL8-4 woofers,

175 W RMS @ 8 Ohms, 350 W program (each woofer)

Enclosure: Multi-ply hardwood, perforated metal grille

Power:

PN82 & PN82R: 115 V AC or 230 V AC, 50/60 Hz

PNX82: 700 W pgm at 4 Ohms

Connectors – PNX82: Screw terminals & looping Neutrik 4-pin SpeakOn style connectors

Finish: Black, white or custom color paint
Natural (unfinished)
Weather Resistant

Hardware Options: 12-point univ. mtg. hdw. (Metric M6 threads)
U-bracket attachment points, Tripod socket,
PN Weather Resistant Kit, Aeroquip Flytrack

Dimensions: 28 1/2" H x 10 3/4" W x 11 1/2" D
(72.4 cm x 27.3 cm x 29.2 cm)

Weight:

PN82 & PN82R: 55 Lbs (24.9 Kg) net

PNX82: 43 Lbs (19.5 Kg) net

PN-1 AMPLIFIER

Power Rating: 300 W RMS @ 8 Ohms

Freq. Response: +0.0, -5 dB, 20 Hz to 20 kHz

THD Distortion: < 0.02% typical

Hum & Noise: <100 dB (A weighted)

Damping: >100

Input: 10K Ohm balanced differential

Sensitivity: 1.0 V for RPO

CMR 74 dB

Controls: Gain (screwdriver adjustable)

Connectors

Input: Looping XLR; female in, male out (pin 1 chassis, pin 2 +, pin 3 -)

Power: EC Power connector

Power: 90-136 VAC or 180-260 VAC 50/60Hz.

4 A @ 120 V, 2 A @ 240 V;

Idle current: 300 mA @ 120 V;

150 mA @ 240 V

Max inrush current: 10 A

PN-1R RHAON EMPOWERED AMPLIFIER

The PN-1R amplifier is identical to the PN-1 except for the addition of the RHAON Network Interface; additional capabilities include:

Inputs: CobraNet; dual RJ45 connectors; accept
CAT 5 copper cable.
AES/EBU Phoenix connectors;
Analog Phoenix connectors

Digital Format: 16, 20 or 24 bit PCM; 48 or 96 kHz sample rate; selectable Network Latency.

Protection: Soft & Peak Limiting, Excursion Control & Thermal Regulation

For additional details on the RHAON Audio Operations Network, refer to www.renkus-heinz.com/Rhaon/Index.html.

Note: All analog inputs and outputs comply with AES Standard 48-2005 on interconnecting, grounding and shielding.

DIMENSIONAL INFORMATION

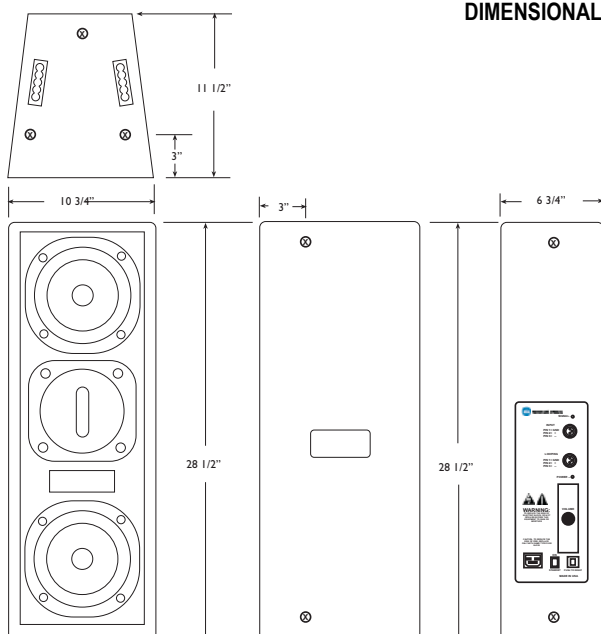

UMH (Universal Mounting Hardware) attachment points are standard on all fixed installation models. The points have Metric M6 threads and are positioned 1 3/4" from the edges unless otherwise indicated. A nut-plate for Omnimount Series 60 mounting hardware may be substituted for the UMH points; can be either top, bottom or side mounted. U-bracket attachment points are a third option.

Portable models are normally supplied with a tripod socket and no attachment points. AeroQuip fly-track, top and bottom mounted, is another option.

Note:

The rear view of a PN82 is shown. The enclosure is shown without its metal grille.

For more detailed dimensional information, please refer to the 2D and 3D drawing files on our website, www.renkus-heinz.com.