

Uncompromised Performance - Unequaled Versatility

The self-powered PowerNet ST4R and non-powered STX4 Series loudspeakers unite advanced technology and application-driven engineering to bring live sound closer to the ultimate reference point: reality. Patented CoEntrant M/H transducers, Class D Digital Tri-Amplification and unique innovations such as our Complex Conic horns combine to deliver natural sounding music and intelligible speech. Wherever audiences and operators demand superior performance and ease of use, ST/STX loudspeakers are the choice for transparent, reference quality performance.

All ST4R PowerNet loudspeakers are RHAON empowered for flexible analog and digital signal distribution and loudspeaker management and control over a standard Ethernet network.

Applications

- Virtually any application where directional control and arrayability are critical issues and outstanding sonic performance is required.
- Distributed systems in sports arenas and stadiums.
- Multi-channel A/V playback systems, live sound and music systems in clubs and disco's (with optional subwoofers).
- Side fill in all types of large sound reinforcement systems.
- Array modules for theatrical and concert sound systems, sound reinforcement systems in houses of worship.



PM-3R PowerNet Tri-Amplifier

Choose external bi-amplification or go self-powered and networked, you can select the system configuration that meets your needs. Select the STX4 when the project dictates the use of external amplifiers and the self-powered PowerNet ST4R for convenience and control in other applications.

The PM-3R, the heart of the PowerNet ST4R is a new kind of intelligent electronic system. It combines Class D digital tri-amplification with RHAON, the Renkus-Heinz Audio Operations Network for comprehensive DSP controlled signal processing and control.

RHAON EMPOWERED RHAON empowers you with CobraNet digital audio distribution, user configurable DSP for maximum control, remote systems management from any Windows computer, life safety functions and more – all using standard Ethernet hardware and cable.

The PM-3R has dual analog inputs, dual CobraNet inputs and an AES3 serial input. The onboard DSP is easily configured using RHAON software; it includes eight bands of parametric EQ, high and low shelving filters, signal delay and input level control. Critical operating parameters such as signal clipping, amplifier output voltage and current, and temperature are continually monitored with automatic alert functions.

ST / STX Series

STX4

Non-Powered

ST4R

Powered

Compact Quad 8" Lows CoEntrant M/H Driver 3-Way Complex Conic Loudspeakers

PASSIVE : POWERED : NETWORKED



• Compact 3-Way Design, Outstanding Performance

Accurate full-range 50 Hz to 18 kHz high-level performance; 133 dB Peak SPL.

• Flexible Input Configurations

Choose external bi-amplification, or go self-powered with the PM3R PowerNet Tri-Amplifier with RHAON for flexible analog and multi-channel digital signal distribution, computer control and supervision.

• Quad-8 Doublet Low Frequency Design

Provides superior low frequency directionality in both horizontal and vertical planes.

• Exclusive Complex Conic Design

Provides constant beamwidth/directivity without the problems of conventional rectangular horns.

• Patented CoEntrant Topology

Integrates the acoustic output of an 8" cone and a 1" HF driver into a wideband, high power true point source.

• TRAP (True Array Principle) Design

ST4/44R and STX4/44 Models are true 40° TRAP modules that combine seamlessly to produce a phase aligned wave front virtually free of lobing.

• Choice of Coverage Patterns

Choose between 40° by 40°, 60° by 40° and 90° by 40° coverage patterns.

TECHNICAL INFORMATION

Sensitivity

ST4R: 1.4 V for rated power output
STX4 (1W/1m): LF: 98 dB, MF: 100 dB, HF: 109 dB
Max Peak SPL:

	ST	STX
LF:	130 dB	133 dB
MF:	129 dB	130 dB
HF:	131 dB	131 dB

Dispersion:

ST4/44R & STX4/44: 40° H by 40° V
ST4/64R & STX4/64: 60° H by 40° V
ST4/94R & STX4/94: 90° H by 40° V
Freq. Response: 50 Hz to 18 kHz

Mid/High Drivers: CDT-1L; SSD1802S-8B 1" HF (40W RMS) & SSL8-9 8" MF (150W RMS)

LF Drivers: Four 8" model SSL8-12 woofers; 2.5" VC ; 200W RMS (800W RMS total)

Crossover Points: 600 Hz & 1500 Hz

Power: STX4: Lows: 800 Watts RMS at 4 Ohms
 Mid/Highs: 150 Watts RMS at 8 Ohms

Enclosure: Multi-ply hardwood, perforated metal grille

Connectors: STX4: Neutrik 4-pin connectors or screw terminals

Finish: Black, white or custom paint , TuffTex, Natural (unfinished), Weather resistant

Hardware Options: 12-point universal mtg hardware , Handles, AeroQuip fly-track, R-Hang hardware

Dimensions: 30 1/4" H x 16 5/8" W x 23 1/2" D
 (76.8 cm x 42.2 cm x 59.7 cm)

Weight

ST4R: 147.5 Lbs. (66.9 Kg) net
STX4: 110 Lbs (49.9 Kg) net

PM-3R AMPLIFIER

PWR Rating (Watts):

Lows: 850 RMS
Mids: 425 RMS
Highs: 175 RMS

Freq. Response: +0.0, -.5 dB, 20 Hz to 20 kHz
THD Distortion: < 0.01 % typical

CMR: > 90 dB, 30 Hz to 2 kHz
Hum & Noise: <100 dB, 20 Hz to 20 kHz
Input Sensitivity: 1.4 V for RPO

Damping Factor: 135 (100 Hz to 400 Hz)
 100 (400 Hz and above)

Power:
Connector PowerCon locking connector

Requirements: 90/136 V AC or 180/260 VAC, 50/60 Hz
 9.6 Amps @ 120 V, 4.8 Amps @ 240 V
Idle Current: 380 mA @ 120 V, 190 mA @ 240 V

Max Inrush Current (Soft Start): 14.5 Amps @ 120 V, 7.3 A @ 240 V

Inputs

Analog: Dual inputs; looping XLR (female in & Male out) & Looping Phoenix connectors

CobraNet: Dual RJ 45 connectors (for redundancy)

AES3 Format: AES3 Format Serial Audio (AES/EBU input); Phoenix connector

Controls:

LF, MF, HF Mute buttons
 Up & Down Output Level push buttons
 10 dB Input pad (on Analog 1 input)
 Power On/Off, Push-To-Reset circuit breaker

Computer Controls: Gain, Mute, On/Standby, Input Selection; Compression, 9-Band Parametric EQ, Shelving & Rolloff Filters, Delay

Status Indicators: Power, Signal, Overdrive, Thermal, Mute, Input Pad

Protection: Soft & Peak Limiting, Excursion Control & Thermal Regulation

Digital Format: 16, 20 or 24 bit PCM; 48 or 96 kHz sample rate; selectable Network Latency.

Note: All analog inputs and outputs comply with AES Standard 48-2005 on interconnecting, grounding and shielding.

DIMENSIONAL INFORMATION

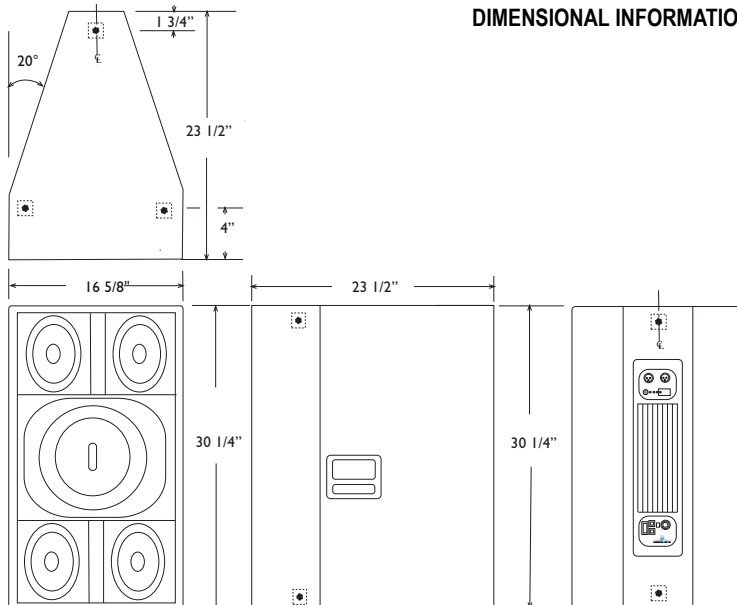

Note:

The UMH (Universal Mounting Hardware) attachment points have Metric M10 threads and are positioned 1 3/4" from the edges unless otherwise indicated. Portable models are normally supplied with handles and no attachment points.

The rear view of a ST4R is shown. The enclosure is shown without its metal grille.

For more detailed dimensional information, please refer to the 2D and 3D drawing files on our website, www.renkus-heinz.com.