



### Uncompromised Performance - Unequaled Versatility

The self-powered PowerNet ST7MR and non-powered STX7M Series loudspeaker modules unite advanced technology and application-driven engineering to bring live sound closer to the ultimate reference point: reality. Patented CoEntrant M/H transducers, Class D Digital Amplification and unique innovations such as our Complex Conic horns combine to deliver natural sounding music and intelligible speech. Wherever audiences and operators demand superior performance and ease of use, ST/STX loudspeakers are the choice for transparent, reference quality performance.

All ST7MR PowerNet loudspeakers are RHAON empowered for flexible analog and digital signal distribution and loudspeaker management and control over a standard Ethernet network.

#### Applications

- Virtually any application where directional control and arrayability are critical issues and outstanding sonic performance is required.
- Distributed systems in sports arenas and stadiums.
- Multi-channel A/V playback systems, live sound and music systems in clubs and disco's (with low frequency cabinets).
- Side fill in all types of large sound reinforcement systems.
- Array modules for theatrical and concert sound systems, sound reinforcement systems in Houses of Worship.



#### PM-2R PowerNet Bi-Amplifier

Passive or self-powered and networked, you can choose the system configuration that meets your needs. Select the STX7M when the project dictates the use of external amplifiers and the self-powered PowerNet ST7MR for convenience and control in other applications.

The PM-2R, the heart of the PowerNet ST7MR is a new kind of intelligent electronic system. It combines Class D digital trig-amplification with RHAON, the Renkus-Heinz Audio Operations Network for comprehensive DSP controlled signal processing and control.

**RHAON** EMPOWERED RHAON empowers you with CobraNet digital audio distribution, user configurable DSP for maximum control, remote systems management from any Windows computer, life safety functions and more – all using standard Ethernet hardware and cable.

The PM-2R has dual analog inputs, dual CobraNet inputs and an AES3 serial input. The onboard DSP is easily configured using RHAON software; it includes eight bands of parametric EQ, high and low shelving filters, delay and input level control. Critical operating parameters such as signal clipping, amplifier output voltage and current, and temperature are continually monitored with automatic alert functions.

## ST / STX Series

### STX7M

Non-Powered

### ST7MR

Powered

### 2-Way High Output Mid/High Complex Conic Loudspeaker Modules

### CoEntrant CDT-2 M/H Driver with 3" Throat

### PASSIVE : POWERED : NETWORKED



- **Compact 2-Way Design, Outstanding Performance**  
Accurate full-range 350 Hz to 18 kHz high-level performance; 135 dB Peak SPL.
- **Flexible Input Configurations**  
Choose passive inputs, or go self-powered with the PM2R Power Net Bi-Amplifier with RHAON for flexible analog and multi-channel digital signal distribution, computer control and supervision.
- **Built-In Mid/High Crossover in STX7M**  
Eliminates need for bi-amping.
- **Exclusive Complex Conic Design**  
Provides constant beamwidth/directivity without the problems of conventional rectangular horns.
- **Patented CoEntrant Topology**  
Integrates the acoustic output of a 10" cone and a 2" HF driver into a wideband, high power true point source
- **TRAP (True Array Principle) Design**  
ST7M/44ASR and STX7M/44 Models are true 40° TRAP modules that combine seamlessly to produce a phase aligned wavefront virtually free of lobing. The /64 and /94 models can be turned into TRAP modules by rotating their horn 90 degrees.
- **Choice of Coverage Patterns**  
Choose between tightly controlled 60° by 40°, 90° by 40° and asymmetrical 40° by 40° (+10°, -30°) coverage patterns.

## TECHNICAL INFORMATION

**Sensitivity**  
**ST7MR:** 1.4 V for rated power output  
**STX7M (1W/1m):** MF – 104 dB, HF – 109 dB

**Max Peak SPL:**

|     | ST     | STX    |
|-----|--------|--------|
| MF: | 133 dB | 135 dB |
| HF: | 134 dB | 134 dB |

**Dispersion:**  
**ST7M/44ASR & STX7M/44AS:** 40° H by Asm. 40° (+10°, -30°) V  
**ST7M/64R & STX7M/64:** 60° H by 40° V  
**ST7/94R & STX7/94:** 90° H by 40° V  
**Freq. Response:** 350 Hz to 18 kHz

**Mid/High Drivers:** CDT-2A; SSD3302-8A 2" HF (75 W RMS) & SSL10-5 10" MF (300 W RMS)

**Crossover Points:** 500 Hz & 1500 Hz  
**Power: STX7M:** Mid/Highs: 300 Watts RMS at 4 Ohms

**Enclosure:** Multi-ply hardwood, perforated metal grille

**Connectors: STX7M:** Neutrik 4-pin connectors or screw terminals

**Finish:** Black, white or custom paint, TuffTex, Natural (unfinished), Weather resistant

**Hardware Options:** 12-point universal mtg hardware, Handles, AeroQuip fly-track, R-Hang hardware

**Dimensions:** 24" H x 24" W x 32 1/4" D  
 (61 cm x 61 cm x 81.9 cm)

**Weight**

**ST7MR:** 170 Lbs. (77.1 Kg) net  
**STX7M:** 140 Lbs. (63.5 Kg) net

## PM-2R AMPLIFIER

**PWR Rating (Watts):**

**Mids:** 425 RMS  
**Highs:** 175 RMS

**Freq. Response:** +0.0, -5 dB, 20 Hz to 20 kHz

**THD Distortion:** < 0.01 % typical

**CMR:** > 90 dB, 30 Hz to 2 kHz

**Hum & Noise:** <100 dB, 20 Hz to 20 kHz)

**Input Sensitivity:** 1.4 V for RPO

**Damping Factor:** 135 (100 Hz to 400 Hz)  
 100 (400 Hz and above)

**Power:**

**Connector** PowerCon locking connector

**Requirements:** 90/136 V AC or 180/260 VAC, 50/60 Hz  
 3.2 Amps @ 120 V, 1.6 Amps @ 240 V

**Idle Current:** 130 mA @ 120 V, 65 mA @ 240 V

**Max inrush current (soft start):** 4.9 Amps @ 120 V, 2.5 A @ 240 V

**Inputs**

**Analog:** Dual inputs; looping XLR (female in & Male out) & Looping Phoenix connectors

**CobraNet:** Dual RJ 45 connectors (for redundancy)

**AES3 Format:** AES3 Format Serial Audio (AES/EBU input); Phoenix connector

**Controls:** MF, HF Mute buttons

Up & Down Output Level push buttons  
 10 dB Input pad (on Analog 1 input)  
 Power On/Off, Push-To-Reset circuit breaker

**Computer Controls:** Gain, Mute, On/Standby, Input Selection; Compression, 9-Band Parametric EQ, Shelving & Rolloff Filters, Delay

**Status Indicators:** Power, Signal, Overdrive, Thermal, Mute, Input Pad

**Protection:** Soft & Peak Limiting, Excursion Control & Thermal Regulation

**Digital Format:** 16, 20 or 24 bit PCM; 48 or 96 kHz sample rate; selectable Network Latency

Note: All analog inputs and outputs comply with AES Standard 48-2005 on interconnecting, grounding and shielding.

## DIMENSIONAL INFORMATION

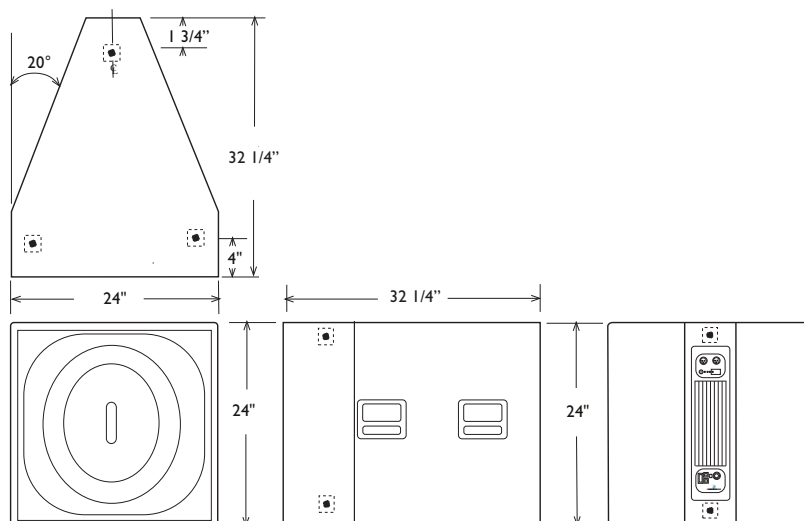

**Note:**

The UMH (Universal Mounting Hardware) attachment points have Metric M10 threads and are positioned 1 3/4" from the edges unless otherwise indicated.

Portable models are normally supplied with handles and no attachment points.

The rear view of a ST7MR is shown. The enclosure is shown without its metal grille.

For more detailed dimensional information, please refer to the 2D and 3D drawing files on our website, [www.renkus-heinz.com](http://www.renkus-heinz.com).