

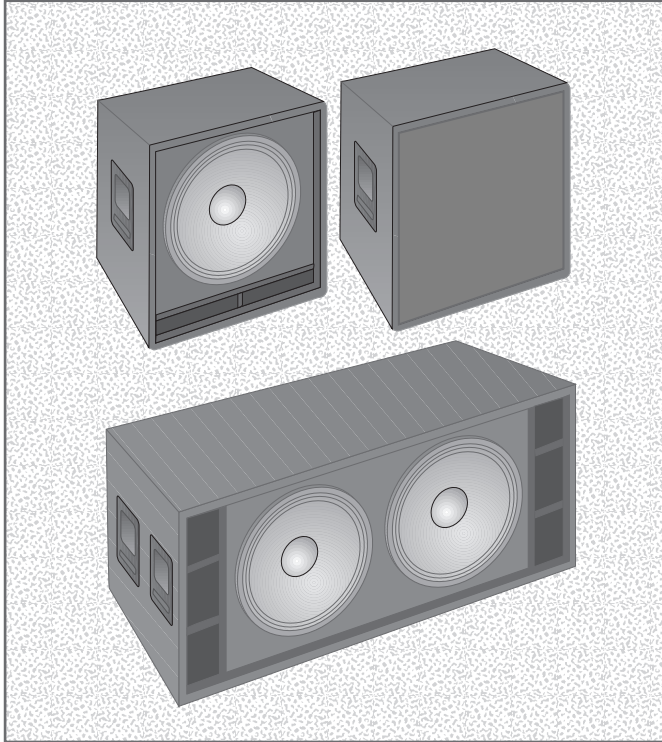

**RENKUS-HEINZ**

MODEL **LR-1A**  
**LR-2A**

**18" Subwoofers**



#### Direct Radiating 18" Subwoofers

The LR-1A and LR-2A were developed specifically for high level entertainment applications needing the powerful sub-bass sound and associated emotional impact obtainable only from direct radiating 18" subwoofers. Their classic sound and proven performance in hundreds of venues over the years have made the LR-1A and LR-2A the choice of audio professional around the world when additional bass is required.

The LR-1A features a single 18" woofer in a 7 3/4 cubic foot cabinet and produces peak SPL levels of up to 129 dB. The dual 18" LR-2A features a 15 1/2 cubic foot cabinet. It handles up to 1200 watts of power and produces peak SPL levels as high as 135 dB. The heavy-duty 18" woofers and optimally tuned and vented, large volume cabinets assure thunderous bass.

#### High Power 18" Woofers

The 18" woofers used in the LR-1A and LR-2A were developed specifically for use in high power sub bass loudspeaker systems. They feature massive motor structures mounted on a rigid cast alloy frame and easily handle 600 watts. A high-temperature edge-wound 4" voice coil with exceptionally long excursion capabilities and a stiff fiber cone assure long term reliability.

#### **POWERFUL 18" SUBWOOFERS**

provide high level (129 dB & 135 dB peak SPL) sub bass performance

#### **LARGE VOLUME ENCLOSURES**

are designed to produce maximum air displacement and to maximize emotional impact

#### **600-WATT WOOFERS**

18" woofers with massive motor structures and 4" edge wound voice coils easily handle 600 watts

#### **HEAVY-DUTY ENCLOSURES**

are constructed from 13-ply hardwood and rigidly braced to withstand abuse and eliminate rattles

#### **CHOICE OF RIGGING METHODS**

choose between fly points and a unique universal mounting hardware system

#### **CHOICE OF FINISHES**

choose between black carpet, durable acrylic paint finishes, natural or weather resistant models

#### Durable Construction

The LR-1A and LR-2A enclosures are ruggedly constructed from durable 13-ply hardwood to withstand the abuse they will receive in portable applications. They are rigidly braced and lined with fiberglass to suppress resonances and eliminate rattles to further assure low distortion high level performance. Heavy perforated steel grilles with moisture resistant foam backing provide further protection from damage.

#### Choice of Rigging Methods

Two methods of flying or hanging these subwoofers are available. Recessed top and/or bottom mounted Fly-Points are ideal for most portable applications. For permanent installations, a unique universal mounting hardware system that provides 12 individual attachment points is more often used. Heavy-duty casters are also available for portable application.

#### Choice of Finishes

The LR-1A and LR-2A are normally furnished with a durable black acrylic resin paint finish, but are also available in an off-white finish, in black carpet or unfinished for fixed installations. Weather resistant versions for high humidity or permanent outdoor applications are also available.

## TECHNICAL SPECIFICATIONS

All specifications are with associated controller

<p><b>SENSITIVITY:</b>  <b>LR-1A:</b> 99 dB (1w/1m)  <b>LR-2A:</b> 102 dB (1w/1m)</p> <p><b>MAXIMUM SPL:</b>  <b>LR-1A:</b> 126 dB cont pgm, 129 dB peak  <b>LR-2A:</b> 132 dB cont pgm, 135 dB peak</p> <p><b>FREQUENCY RESPONSE:</b> 35 Hz to 250 Hz</p> <p><b>DRIVER:</b> Model SSL 18-3; 18", 600 watt, 8 ohms</p> <p><b>POWER RATING:</b>  <b>LR-1A:</b> 600 watts at 8 ohms  <b>LR-2A:</b> 1200 watts at 4 ohms</p> <p><b>ENCLOSURE:</b> 13 ply hardwood, heavily braced</p> <p><b>GRILLE:</b> Perforated metal grille with moisture resistant foam insert</p> <p><b>OPTIONS:</b> Handles (standard) Heavy duty casters</p>	<p><b>CONNECTOR OPTIONS:</b> Neutrik NL4MPR or screw terminals</p> <p><b>FINISH OPTIONS:</b> Black carpet Black or off-white paint Natural (unfinished) Weather resistant (suffix WR)</p> <p><b>HARDWARE OPTIONS:</b> Model FP-4 Fly-Points or UMH-12 -3/8 mounting hardware</p> <p><b>DIMENSIONS:</b>  <b>LR-1A:</b> 27" H x 22 1/2" W x 22 1/2" D 68.6 cm x 57.2 cm x 57.2 cm   <b>LR-2A:</b> 24" H x 48" W x 24" D 61 cm x 121.9 cm x 61 cm</p> <p><b>NET WEIGHT:</b>  <b>LR-1A:</b> 85 Lbs (38.56 kg)  <b>LR-2A:</b> 175 Lbs. (79.4 kg).</p> <p><b>ASSOCIATED EQUIPMENT:</b> X-120B dual channel controller X-220L dual channel controller</p>
---	--

## DIMENSIONAL INFORMATION

