



RENKUS-HEINZ



TRAP42 SERIES

3-Way TRAP SERIES Loudspeaker Systems



EXCLUSIVE COENTRANT DESIGN (U.S. Pat. 5,526,456)

provides true point source performance with outstanding resolution and tonal clarity

TIGHTLY CONTROLLED BROADBAND COVERAGE

CoEntrant Waveguide Technology provides wide band control with constant Q through crossover

TRAP "TRUE ARRAY PRINCIPLE" DESIGN

assures coincident acoustic centers and minimal comb filtering in tight packed arrays

CHOICE OF VERTICAL COVERAGE PATTERNS

choose between symmetrical 60° vertical coverage and asymmetrical 75° vertical coverage

POWERFUL LOW FREQUENCY SECTION

dual heavy-duty 15" woofers provide solid bass down to 40 Hz

BUILT-IN MID/HIGH FREQUENCY CROSSOVER

eliminates the need for tri-amplification, thereby reducing system cost

Exclusive CoEntrant Design

The full-range TRAP42 Series loudspeakers are 3-way systems developed for applications that require the very best in overall sound performance. They feature CoEntrant Waveguide Technology, a Renkus-Heinz breakthrough in loudspeaker design that provides true point source performance along with natural signal alignment and tightly controlled dispersion. The end result is unprecedented sound clarity and near perfect imaging, even at high SPL levels. The CoEntrant design also provides tight pattern control in both planes down to 500 Hz. TRAP42 loudspeakers are packaged in 40° trapezoidal enclosures that assure controlled, even coverage in either small or large arrays when the cabinets are close coupled along their 20° sides.

Choice of Vertical Coverage Patterns

The TRAP42/6 offers 60° vertical coverage, while the TRAP42/7 provides asymmetrical 75° (plus 30° and minus 45°) coverage to direct more sound onto the audience area.

True Point Source Performance

The unique CoEntrant design of these loudspeakers ensures proper signal alignment and constant directivity and "Q" through crossover. This enables them to provide tonal balance and resolution not attainable from other designs.

TRAP "True Array Principle" Design

The TRAP "True Array Principle" design of the CoEntrant Waveguides used in these loudspeakers and the design of their cabinets place the acoustic centers of tight packed cabinets in almost perfect alignment. This allows the spherical wavefronts to combine in a coherent manner and drastically reduces comb filtering while assuring consistent frequency response within the cluster's coverage area. Their 40° trapezoidal design (20° sides) and broadband 40° horizontal coverage also turn these loudspeakers into true 40° array modules. In an array, each module combines smoothly with the adjacent module(s) to add 40° to the horizontal coverage.

Custom Flexibility

TRAP42 Series loudspeakers are available for either portable use or for use in permanent installations. Portable models are normally carpeted in black and provided with handles and Neutrik connectors. Fixed installation models are usually painted black and supplied with screw terminals and universal mounting hardware in place of the handles and connectors. Optional finishes include white paint and "natural" (unfinished) to allow customizing. Weather resistant models are also available. Mounting hardware choices include Aeroquip track fittings and a 12-point universal mounting hardware system.

TRAP42 SERIES TECHNICAL SPECIFICATIONS

All specifications are with associated controller

SENSITIVITY: 101 dB (1w/1m) @ 300 Hz
MAXIMUM SPL: TRAP42/6; 134 dB program
DISPERSION: TRAP42/7; 133 dB program

TRAP42/6: 40° H by 60° V
TRAP42/7: 40° H by 75° V (+30°, -45°)

FREQUENCY RESPONSE: 40 Hz to 17,000 Hz

HIGH FREQUENCY DRIVERS: Dual 1" SDA200-16, 80 W RMS at 8 ohms (total), 160 W pgm (total)

MID FREQUENCY DRIVERS: Two SSL6.5-3, 6.5" cone driver, 260 W RMS at 8 ohms (total), 520 watts program (total)

LOW FREQUENCY DRIVERS: Dual SSL15-6 15" woofers, 800 W RMS @ 4 ohms (total), 1600 W pgm

CROSSOVER POINT: 350 Hz

CONNECTOR OPTIONS : 4-pin Neutrik, screw terminals

ENCLOSURE 13 ply hardwood, heavily braced

GRILLE: Perforated metal grille with moisture resistant foam insert

CONNECTORS: Screw terminals, Neutrik 4-pin connectors

FINISH OPTIONS: Black, white or custom color paint, black carpet, natural, weather resistant

HARDWARE OPTIONS: 3/8-16 12-point univ. mtg. hdw., Aeroquip track (top & bottom) handles

DIMENSIONS: 57 1/2" H x 16 5/8" W x 23 1/4" D (146.1 cm x 42.2 cm x 59.1 cm)

NET WEIGHT: 166 Lbs. (75.3 Kg)

ASSOCIATED EQUIPMENT: X Series controllers

DIMENSIONAL INFORMATION

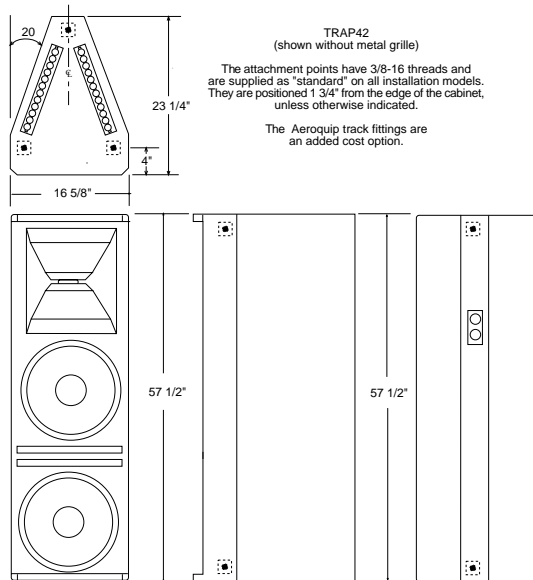

ARRAY COVERAGE

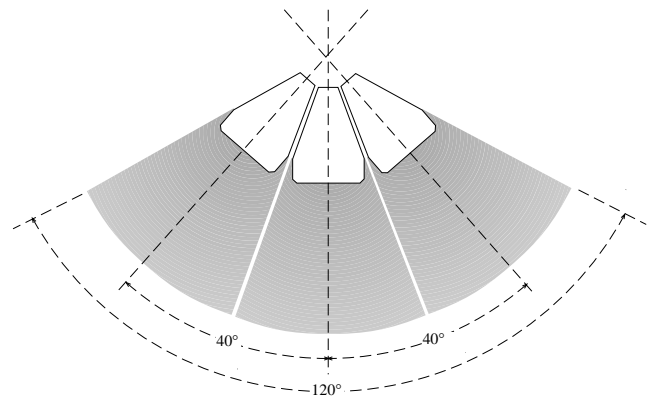

TRAP42 Array Coverage

ARCHITECTS AND ENGINEERS SPECIFICATIONS

The loudspeaker shall be a Renkus-Heinz Model () or approved equal 3-way CoEntrant system offering true point source performance.

The loudspeaker system shall consist of dual 6.5" carbon fiber cone MF drivers and dual extended-range 1" HF drivers coupled to a single mid/high frequency horn plus dual heavy-duty 15" woofers, all mounted in a 40° trapezoidal enclosure. The system shall include a built-in mid/HF crossover and provide (40° H° by 60° V) (40° H by 75° asymmetrical V) coverage.

The loudspeakers HF power handling capacity shall be no less than 80 W RMS @ 8 ohms, mids 260 W RMS @ 8 ohms and lows 800 W RMS @ 4 ohms. Sensitivity shall be no less than 101 dB, 1w, 1m @ 300 Hz with a maximum SPL of at least () dB and a frequency response of 40 Hz to 17 kHz.

The enclosure shall be trapezoidal in shape and constructed from 13 ply birch, heavily braced and lined with fiberglass to suppress resonances. It shall be no larger than 57 1/2" high and 16 5/8" wide, be no deeper than 23 1/4", and weigh no more than 166 Lbs. A matching perforated metal grille backed with protective foam shall be included. The finish shall be (black carpet) (black paint) (white paint) (natural) (weather resistant). Connectors shall be (4-pin Neutrik) (screw type terminals). [The enclosure shall be equipped with (handles) (universal mounting hardware offering 12 3/8-16 attachment points) (Aeroquip track fittings top and bottom mounted).]

The speaker system shall be designed for use with an associated Renkus-Heinz "X" Series controller or approved equal. The controller shall provide fixed crossover points, response equalization and protection from overload damage.



19201 Cook Street, Foothill Ranch, CA 92610-3501

Tel: 949-588-9997 Fax: 949-588-9514 E-mail: Sales@renkus-heinz.com Web: www.rh.com

RH 342 21/98