

### Outstanding Performance, Unequaled Versatility

TRX Series loudspeakers use advanced technology and application-driven engineering to bring live sound closer to the ultimate reference point: reality. Cutting edge driver technology and unique innovations such as our Complex Conic horns deliver natural sounding music and intelligible speech.

Versatile enclosure designs, combined with a wide range of mounting options and associated hardware, provide unrestricted flexibility for both portable and installed applications. Wherever audiences and operators demand superior performance and ease of use, TRX Series loudspeakers are the choice for unequalled value.

#### Applications

- Virtually any application where size is important and high output and outstanding sonic performance are required.
- Ideal for multi-channel playback systems in clubs and disco's (with optional subwoofers.)
- Distributed sound reinforcement systems in sports arenas and stadiums.
- Side fill loudspeakers in sound reinforcement systems.
- High output floor monitors in live sound venues.

### Advanced Complex Conic Horn Design



Designed around the spherical expansion of the acoustic pressure wave, Complex Conic horns provide constant beamwidth/directivity without the problems of conventional rectangular horns. These unique waveguides eliminate low frequency "pattern flip"; have no corners to cause high frequency "feathering" and the resulting pattern distortion.

With extended pattern bandwidth, lower distortion and minimal coloration, Complex Conic horns work better and sound far more natural than ordinary horns.

Nominal Coverage Patterns  
(90° by 40°, for example)



Actual patterns clearly show superior pattern control of Complex Conic Horns

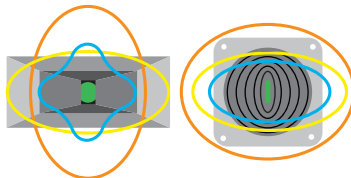

Frequency Bar - low frequencies (red) to high frequencies (blue)



## TRX Series

### TRX151

#### 15" Woofer + 1" HF 2-Way Complex Conic Loudspeaker System



#### • Compact Multi-Function Design

Outstanding, full-range, 50 Hz to 18 kHz performance in a versatile multi-angle enclosure.

#### • Exclusive Complex Conic Design

Complex Conic horns provide superior pattern control with low distortion.

#### • Choice of Coverage Patterns

Complex Conic horns provide smooth 60° by 40° or 90° by 40° coverage, may be rotated 90° within cabinet.

#### • 1" Extended Range HF Driver

Provides smooth, low distortion high frequency performance to 18 kHz and beyond.

#### • Heavy-Duty 15" Woofer

With treated fiber cone easily handles 700 Watts of program power.

#### • Built-in Crossover

Eliminates need for a separate electronic crossover and bi-amplification.

## TECHNICAL INFORMATION

<b>Sensitivity:</b>	99 dB (1W/1m) @ 500 Hz	<b>Enclosure:</b>	Multi-ply hardwood, perforated metal grille
<b>Maximum SPL:</b>	127 dB program, 130 dB Peak	<b>Connectors:</b>	Screw terminals or Neutrik 4-pin connectors
<b>Dispersion:</b>	(TRX151/6) 90° H by 40° V* (TRX151/9) 90° H by 40° V*	<b>Finish Options:</b>	Black or white paint Custom colors Natural (unfinished) Weather resistant
<b>Frequency Response:</b>	50 Hz to 18 kHz	<b>Hardware Options:</b>	12-point univ. mtg. hdw. Omnimount Series 120 nut-plate U-bracket Tripod socket & handles
<b>HF Driver:</b>	1" SSD202-8 driver, 40 W RMS, 80 W program	<b>Dimensions:</b>	29 1/4" H x 17 1/4" W x 14 1/2" D (74.3cm x 43.8 cm x 36.2 cm)
<b>LF Driver:</b>	15" model SSL15-13 woofer, 3" VC, treated fiber cone; 350 W RMS, 700 Watts program	<b>Net Weight:</b>	53 Lbs (20 Kg) net
<b>Crossover Point:</b>	1.8 kHz		
<b>Power Rating:</b>	700 Watts program at 8 Ohms		

**Note:** Complex Conic horns may be rotated 90 degrees within the enclosure.

## DIMENSIONAL INFORMATION

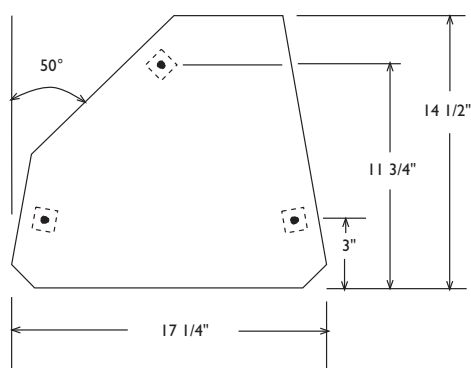

UMH (Universal Mounting Hardware) attachment points are standard on all fixed installation models. The points have Metric M10 threads and are positioned 1 3/4" from the edges unless otherwise indicated. A nut plate for Omnimount Series 120 mounting hardware may be substituted for the UMH points; can be either top, bottom or side mounted. U-bracket attachment points are a third option.

Portable models are normally supplied with handles and a tripod socket and no attachment points.

The enclosure is shown without its metal grille. For more detailed dimensional information, please refer to the 2D and 3D drawing files on our website, [www.renkus-heinz.com](http://www.renkus-heinz.com).

