

## Unexcelled Performance and Versatility

Developed with versatility in mind, VARIA loudspeaker systems perform flawlessly in all types of portable applications and in fixed installations. Their audio-ophile quality transducers and skilful design combine to deliver unprecedented performance and control in any environment.

The 15 degree -15 series of cabinets are used mainly in medium-throw applications like the center cabinets of a tall vertical line array or in smaller 2 or 3 cabinet systems. They also perform well as a single cabinet pole mounted loudspeaker.

RHAON, the Renkus-Heinz Audio Operations Network extends control and supervision of the loudspeaker system to your computer and your fingertips even if you are seated hundreds of feet away from the loudspeakers.

### Applications

- Almost any application where sonic performance requirements and coverage needs cannot be met with conventional loudspeakers.
  - Live sound reinforcement in large and small venues; night clubs, houses of worship, performing arts centers and auditoriums, etc.
- Outdoor events, company picnics, political rallies, holiday celebrations.

**VERSATILE    POWERFUL    MUSICAL**

### Flexibility

VA101 systems are self-powered for convenience and flexibility; VAX101 systems are designed for use with external amplifiers. Both can be used as a stand alone system either with or without an associated subwoofer. They can be pole mounted on their matching subwoofer or on a tripod stand using their multi-angle pole socket.

In applications needing more power and control they can be floor mounted or arrayed in either horizontal clusters or in vertical line arrays.

Both are also available in weather resistant models suitable for outdoor installations

VAX101 models include a balance control that allows adjustment of their high frequency levels to maintain the natural balance between the highs and lows. Self powered VA101 models include a built-in 8-band parametric EQ that provides full control over their frequency response.

### RHAON Equipped Class D Digital Amplifier

The Renkus-Heinz PF2-500R Class D digital bi-amplifier integral to the VA101 combines digital bi-amplification with RHAON DSP and control into a single efficient and lightweight unit. The onboard DSP includes 8 bands of parametric EQ, high and low frequency shelving filters, input level control and up to 340 msec of signal delay. Critical operating parameters such as signal clipping, output voltage and current and temperature are continually monitored with automatic alert functions.

© 2012 Renkus-Heinz Inc. reserves the right to change any product specification without prior notification.

## Modular Point Source Array Systems

# VARIA

**VA101-15-52R & VAX101-15**  
15° Array Modules

**Medium Throw**



- **Outstanding Performance**  
Provide point source clarity with the pattern control and high level performance of line arrays
- **Dual 1" HF Drivers and High Power 10" Woofer**  
With Neodymium magnets deliver smooth, low distortion 126 dB peak SPL performance from 60 Hz to 20 kHz.
- **Great Versatility**  
Can be used as a stand-alone "medium throw" loudspeaker, as an array module in horizontal arrays or in ground stacked, pole mounted or flown vertical line arrays.
- **Exclusive Tuned Conic Diverter**  
Provides constant beamwidth / directivity down to 300 Hz.
- **Tight Pattern Control**  
Allows 15° modules to be mixed with 7.5° and 22.5° in arrays to provide asymmetrical coverage patterns.
- **Reliable, Easy-To-Use Hardware**  
Assemble easily, safely stack or fly in multi-cabinet arrays with subwoofers.
- **Flexible Input Configurations**  
Choose passive inputs, or go self-powered with the RHAON empowered class D digital PF2-500R bi-amplifier.

**Multi-Angle Pole Socket**

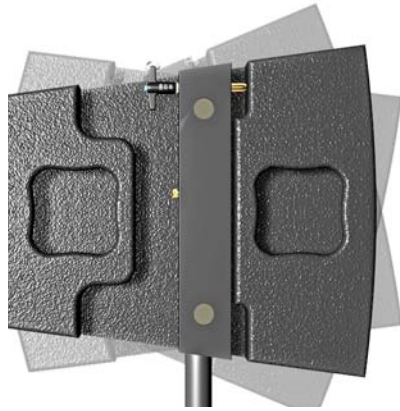

**Heavy Duty Hardware with Quick Release Pins**



**Adjustable HF Balance Control**



**EASE Balloon showing Trapezoidal Coverage**

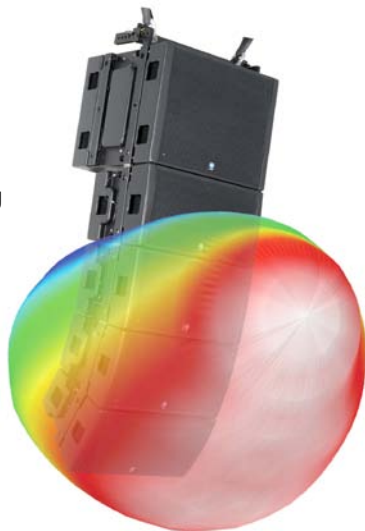

**Versatile • Powerful • Dependable**

VARIA loudspeakers were designed to take the abuse they will face in portable applications and to conquer the many challenges they will face in everyday usage.

Simple, rugged, integral hardware provides maximum versatility, maximum safety, and fast setup and tear down. Metric M10 attachment points allow individual modules to be easily flown using eye bolts.

Threaded 35 mm pole sockets on the subwoofers and multi-angle pole sockets on the full range cabinets allow one or two of the full range array modules to be pole mounted on the subwoofers and aimed

Multiple full range modules can also be ground stacked using one or more of the matching subwoofers as a base. The subwoofers can also be used as a platform for flying the full range modules beneath them. Up to 6 full range modules and two subwoofers can easily and safely be flown in this fashion.

The array modules and subwoofers are joined together with heavy-duty tie bars and quick-disconnect pins that provide easy assembly along with metal-to-metal reliability. An associated fly-bar that attaches easily to the subwoofer completes the package.

An adjustable HF balance control panel on each externally powered full range module allows you to adjust the high frequency output of each module to compensate for the changes in high frequency coupling that occurs between adjacent modules in multi-module line arrays.

It is invaluable in helping you assure that every member of the audience receives the same well balanced sound, even those seated in the rear of the audience area.

Self powered VA101 modules include the RHAON empowered PF2-500R digital amplifier which provides for even greater control of each modules response

All VARIA full-range modules can be configured with traditional fixed-dispersion waveguides or with transitional waveguides, allowing the dispersion to be matched to the venue.

VARIA101 loudspeakers come standard with waveguides that provide the 90° horizontal coverage preferred by many portable system operators. For fixed installations, or for special-purpose rental inventory, VARIA loudspeakers can be equipped with either 60° or 120° waveguides, or with the new transitional waveguides that provide coverage that transitions from 60° to 90° or from 90° to 120°. Please refer to the last page of this document for a complete listing of available coverage patterns.

These revolutionary new transitional waveguides deliver horizontal coverage that transitions seamlessly from one angle to another within a single cabinet. This eliminates issues associated with using different waveguides in adjacent cabinets, ensuring optimal performance.

Arrays can now be designed with 60° horizontal coverage at the top for the longest throw, and 120° at the bottom for down fill, providing the trapezoidal coverage pattern ideal for many rectangular shaped rooms. This versatility, coupled with the power density control of the three cabinet angles, and the ease of DSP gain-shading in RHAON amplifier modules, delivers a highly flexible solution to the challenges of performance venues around the world.

## Modular Point Source Arrays

VARIA array modules are available in three basic cabinet styles; a 7.5° long throw module usually used at the top of vertical arrays, a 15° medium throw module for general use and in the center of vertical arrays and a 22,5° near field module that is ideal for horizontal arrays. All also perform admirably as stand alone loudspeakers.

With their unique design and tightly controlled coverage patterns, VARIA performs equally well in horizontal point source arrays – for example, as a center channel array in an LCR design.

VARIA 22.5° cabinets have been designed to fly either as modules in a vertical array, or as part of a tight-packed horizontal array. The system designer or sound engineer can build horizontal coverage in 22.5° “slices” as required, with seamless integration between cabinets – a true Modular Point Source solution.

In horizontal clusters, VARIA’s unique waveguide design makes building asymmetric coverage fast and easy. In addition to the standard 60°, 90°, and 120° vertical coverage angles available, asymmetric 75° (+30° /-45°) models are available, reducing the amount of mechanical down tilt required.

The same intuitive, integral, interlocking hardware that makes VARIA easy to deploy in line array applications also ensures seamless, tight-packed, horizontal clusters. An array of two enclosures can be suspended from a single point using a single RHANG101H pickup bar; three or four wide clusters require two RHANG101H units.

Typical Ground Stack



Typical Vertical Array



Typical 2-wide Horizontal Cluster using two VA/VAX101-22

## EASE Focus II Simulation Software

VARIA101 DLL data in EASE and EASE Focus II simulation software tools allows users and system designers to quickly and accurately predict the response of the array.

Simply define the audience areas and you can easily position the array, add or remove cabinets, and adjust its height, location and angle until you achieve the desired results in the simulation.

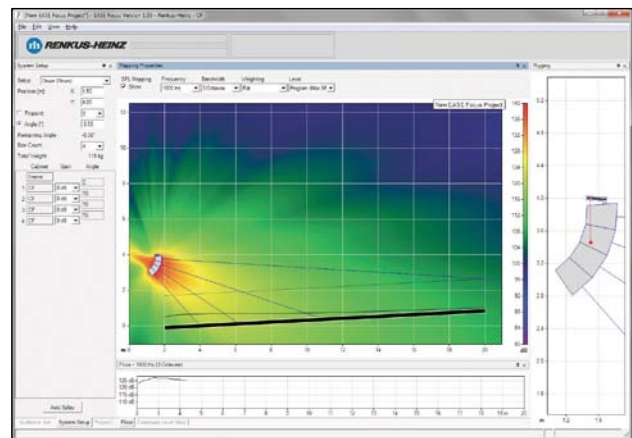

## RHAON

RHAON is the first practical system to combine individual loudspeaker control and supervision of self-powered loudspeaker systems with digital audio distribution. RHAON puts you in total control of:

- A powerful DSP inside each loudspeaker on the Ethernet network that includes eight bands of parametric EQ, high and low frequency shelving filters, input level control, muting and up to 340 ms of delay.
- Monitoring of each loudspeakers critical operating parameters such as signal clipping, amplifier output voltage and current and temperature with automatic alert functions.
- Real time digital audio distribution over standard Ethernet networks using proven CobraNet technology to deliver multiple channels of high quality digital audio over a CAT 5 cable.

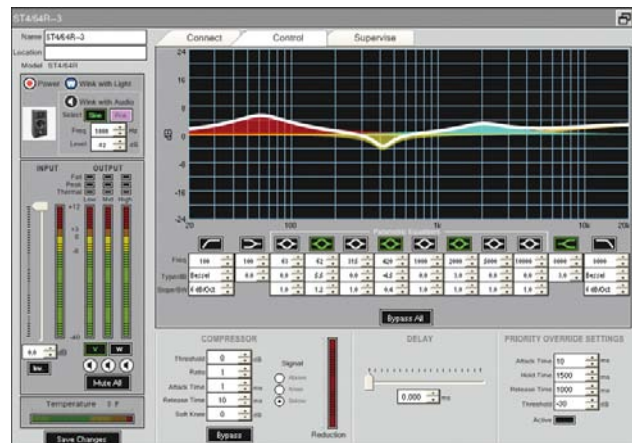

# VARIA

## VA101-15-52R & VAX101-15 Technical Specifications

**Sensitivity**  
**VA101-15-5R:** 1.0 V for RPO  
**VAX101-15:** 96 dB (1W/1m)

**Freq. Range:** 60 Hz to 20 kHz

**Max SPL:** 126 dB peak @ 1 meter

**Horiz. Dispersion:** 90° standard, 60° & 120° available,  
 Transitional 60° to 90° & 90° to 120° also available

**Vert. Dispersion:** 15 degrees, 7.5° and 22.5° models also available)

**Dimensions:** 23 3/4" W x 13" H x 15" D

**Weight -VA101-15-52R:** 67.5 Lbs, 30.6 kg  
**VAX101-15:** 63.5 Lbs, 28.8 kg

**Power Rating:** VAX101-15: 250 W RMS @ 4 Ohms, 500 W pgm

**Enclosure:** Multi-ply hardwood with perforated steel grill

**Transducers:** Dual 1" HF drivers, RH model SSD1750-TN-8  
 each 75 Watts RMS, 150 Watts pgm  
**VA101-15-5R:** 10" woofer; RH model SSL10-7-4,  
 4 Ohms, 250 Watts RMS, 500 Watts pgm  
**VAX101-15:** 10" woofer; RH model SSL10-7,  
 8 Ohms, 250 Watts RMS, 500 Watts pgm

**Connectors:**  
**VAX101-15:** Looping Neutrik Speakon, screw terminals

### PF2-500R Bi-amplifier

**Power Rating:** LF, 500 Watts RMS @ 4 Ohms,  
 HF, 100 Watts RMS @ 4 Ohms

**THD Distortion:** < 0.02% typical  
**Hum & Noise:** <100 dB (A weighted)

**Damping:** >100  
**Input:** 10K Ohm balanced differential  
**CMR:** 74 dB  
**Controls:** Level, Mute, 10 dB Input Pad

**Power Connector:** IEC Power connector  
**Input:** Switchable, 115 or 230 V AC, 50/60 Hz  
**Power:** 5 A @ 120 V, 2.5 A @ 240 V  
 Idle current: 400 ma @120 V; 200 ma @ 240 V  
 Max inrush current: 1 A

**Inputs:** **CobraNet:** Dual RJ45 connectors; accept  
 Cat 5 copper cable.  
**AES/EBU:** Phoenix connectors;  
**Analog:** Looping XLR; female in, male out  
 pin 1 chassis, pin 2 +, pin 3 -)

**Digital Format** 16, 20 or 24 bit PCM;  
 48 or 96 kHz sample rate;  
 Selectable Network Latency.

## Dimensional Information

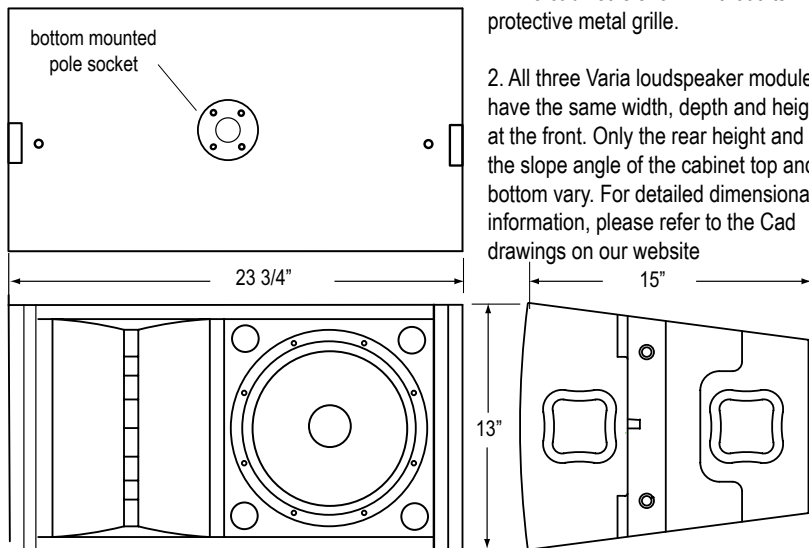

## Model Number & Horizontal Coverage Cross Reference

### VAX101-15 Series - Externally Powered

**VAX101-15/6:** 60°  
**VAX101-15/9:** 90°  
**VAX101-15/12:** 120°  
**VAX101-15/69:** 60° to 90° transitional waveguide  
**VAX101-15/912:** 90° to 120° transitional waveguide

### VA101-15-52R Series - Self Powered

**VA101-15/6-52R:** 60°  
**VA101-15/9-52R:** 90°  
**VA101-15/12-52R:** 120°  
**VA101-15/69-52R:** 60° to 90° transitional waveguide  
**VA101-15/912 -52R:** 90° to 120° transitional waveguide